

XI Marine Energy Conference

INTEGRIA

Research into structural INTEGRity in floating offshore wind using models based on Artificial Intelligence



Artificial intelligence to assist key elements of floating wind turbines

Bilbao – May 28



Fondo Europeo de Desarrollo Regional (FEDER)
"Una manera de hacer Europa"

Eskualde Garapenerako Europar Funtsa (EGEF)
"Europa egiteko modu bat"

Proyecto subvencionado por el Departamento de Desarrollo Económico, Sostenibilidad y Medio Ambiente del Gobierno Vasco (Programa HAZITEK 2023) y el Fondo Europeo de Desarrollo Regional (FEDER 2021 – 2027) Eusko Jaurlaritzaren Ekonomiaren Garapen, Jasangarritasun eta Ingurumen Saila (HAZITEK 2023 Programa) eta Eskualde Garapenerako Europar Funtsak diruz lagundutako proiektua (EGEF 2021 – 2027)
Project funded by the Department of Economic Development, Sustainability and Environment of the Basque Government (HAZITEK 2023 Programme) and the European Regional Development Fund (ERDF 2021 – 2027)

Index

1. - **IntegrIA project Introduction**
2. - **Digital model architecture**
3. - **AI models for TP Stress forecasting**
4. - **Metoceanic AI model**

Index

1. - IntegrIA project Introduction
2. - Digital model architecture
3. - AI models for TP Stress forecasting
4. - Metoceanic AI model

IntegrIA project Introduction

- **INTEGRIA's** overall objective is research into the structural integrity of high-value-added components, enabling companies to access the enormous potential market for floating offshore wind power.
- Achieving this is only possible with **models as a key means of solving problems** with innovations around the generation of a single comprehensive model made up of several digital models based on Artificial Intelligence (AI) of elements of the structure (transition piece, TP), the mooring system, the evacuation and power supply elements, the access system or the hydraulic and mechanical systems for the control of the floating wind turbine.



Offshore wind energy is crucial for meeting European Green Deal goals,

Index

1. - **IntegrIA project Introduction**
2. - **Digital model architecture**
3. - **AI models for TP Stress forecasting**
4. - **Metoceanic AI model**

IntegrIA – Digital Model Architecture

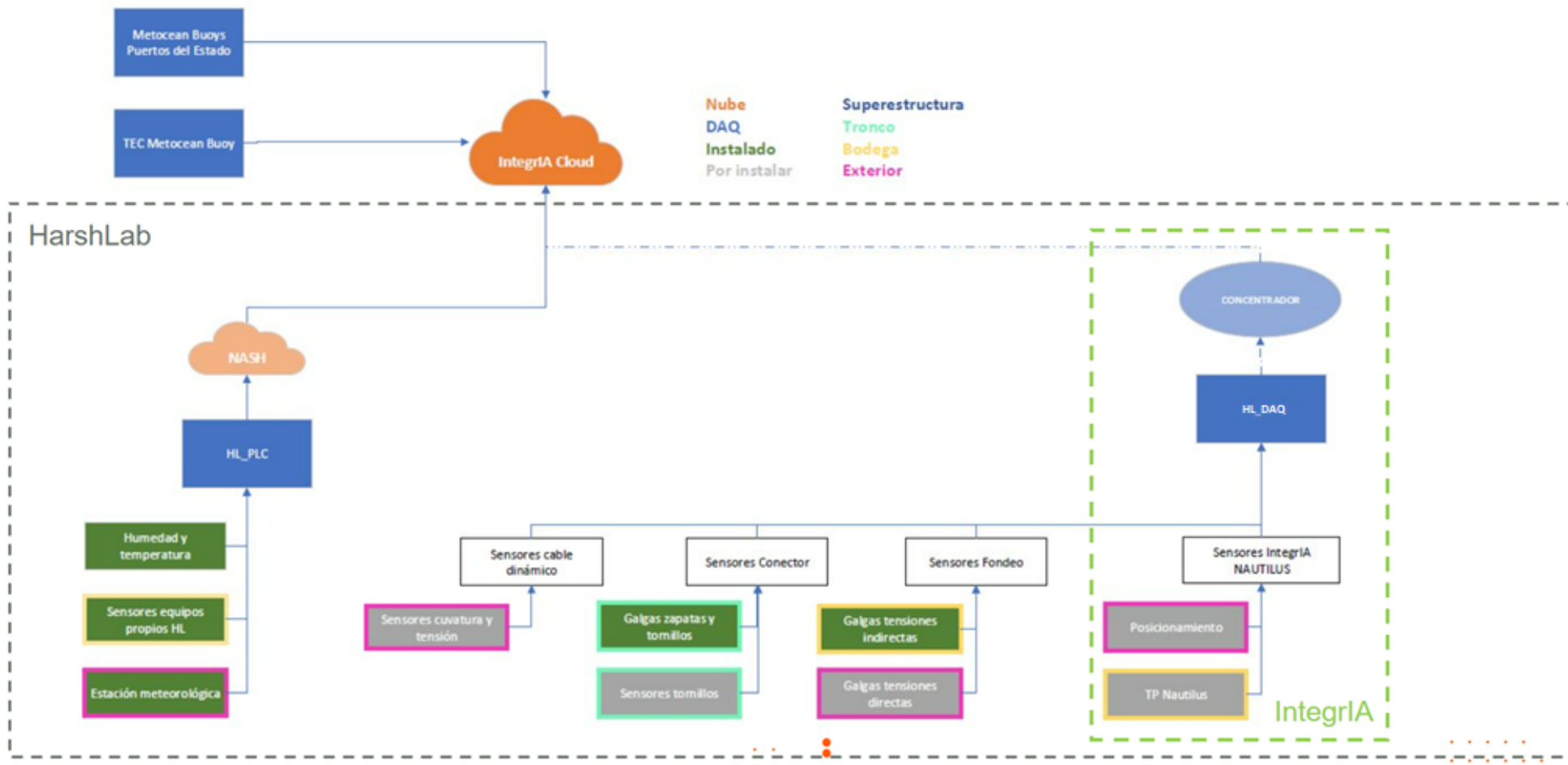

IntegrIA – Digital Model Architecture

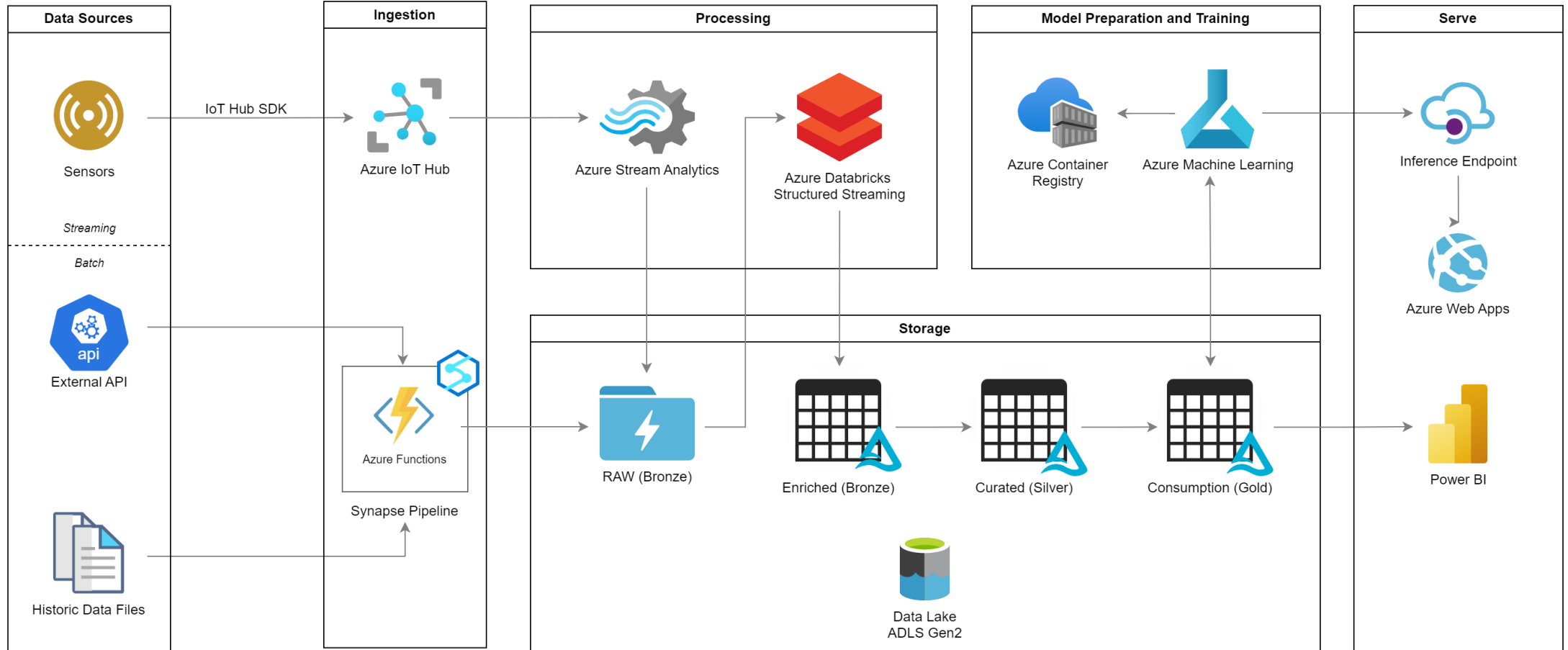

Index

1. - **IntegrIA project Introduction**
2. - **Digital model architecture**
3. - **AI models for TP Stress forecasting**
4. - **Metoceanic AI model**

IntegrIA – AI models for TP Stress forecasting

Transition Piece is one of the most important elements from structural point of view, it's responsible for connecting the wind turbine with the floating structure and transmitting the loads.

The objective is to create predictive AI model for stress assessment and forecasting in the Transition Piece (TP) of floating wind turbines, a key structural element requiring robust performance under fluctuating environmental and operational forces.

- Real data
- Mathematical model calibration/validation



IntegrIA – AI models for TP Stress forecasting

To address the limitations of acquiring extensive real-world data, the system relies on synthetic data, with principal Design Load Cases defined to encompass a broader range of dynamic scenarios.

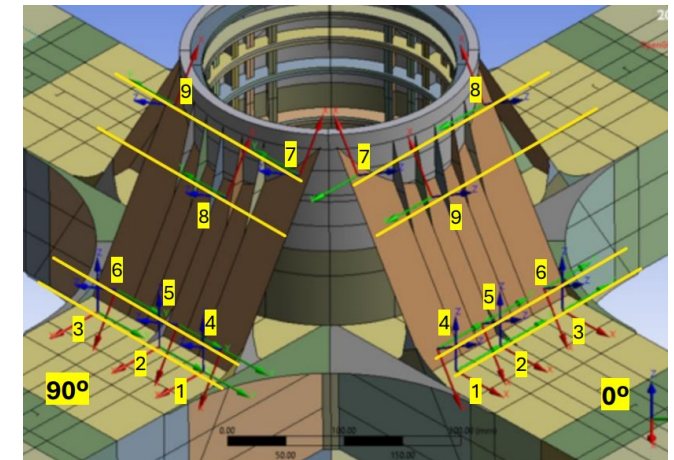
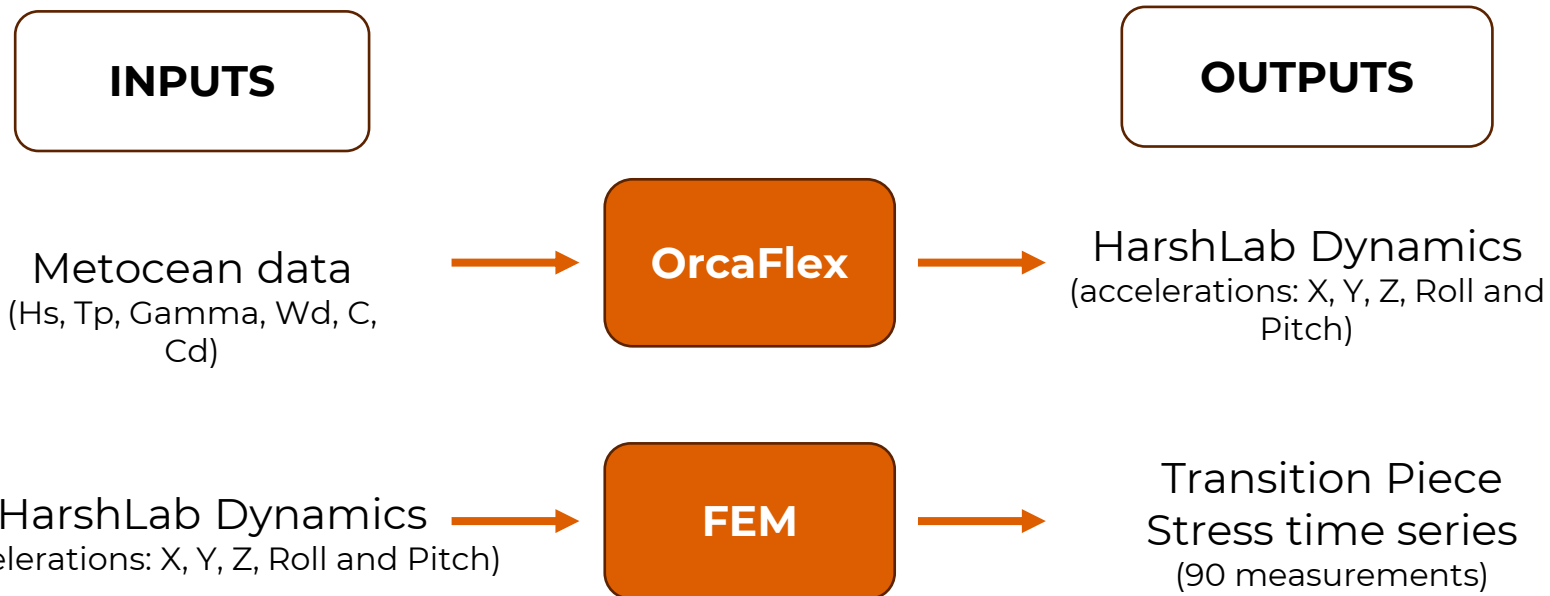

IntegrIA – AI models for TP Stress forecasting

EXPLORATORY DATA ANALYSIS

DLC: Hs 11 / Tp 18.2 / Gamma 3.3
/ Wd 315 / C 1.4 / Cd 270

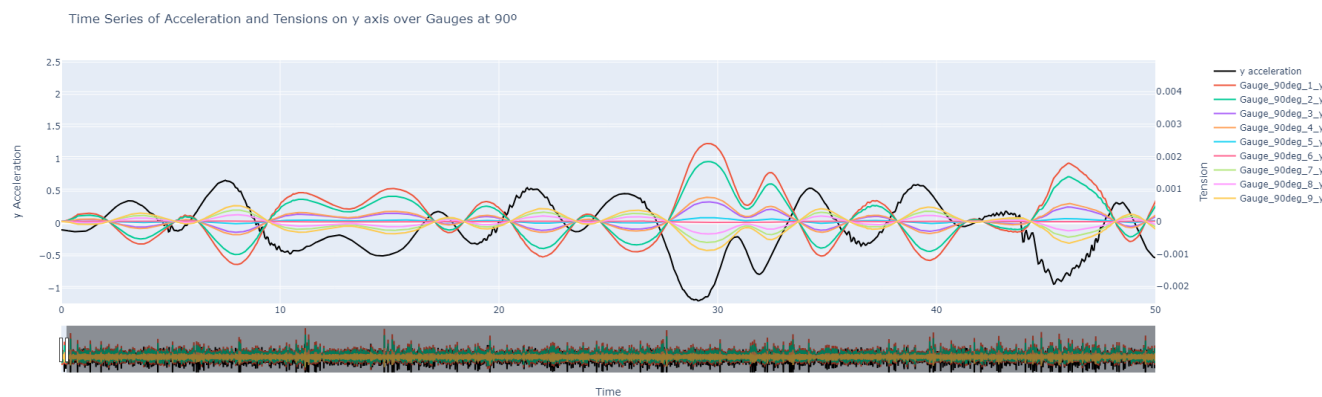
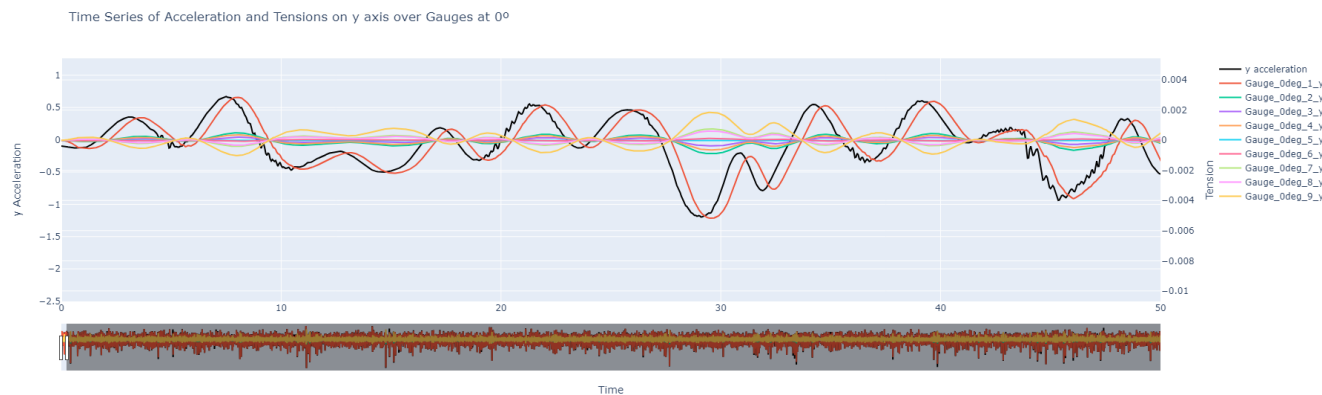

IntegrIA – AI TP strain forecasting model

EXPLORATORY DATA ANALYSIS

CASE Gamma 3.3 (20Hz)

Lagged Correlation of X Acceleration vs. Tension

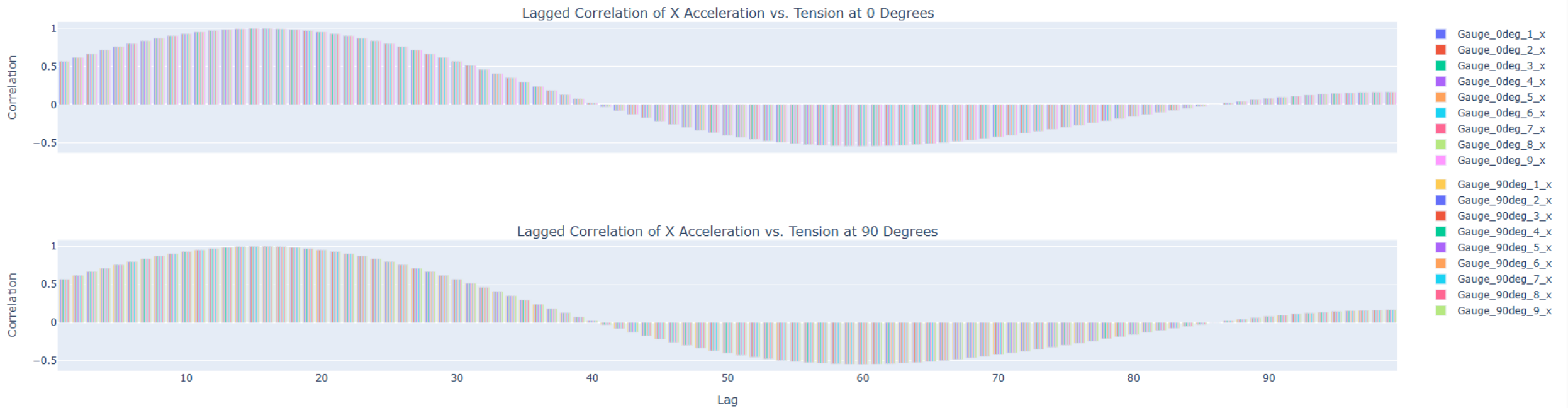

IntegrIA – AI TP Stress forecasting model

TP STRESS PREDICTION (Regression models)

Input(10): Accelerations On t_{-15} , t_{-16} → Output(90): Stress contributions on t_0



+

QuantileTransformer('normal')

Model	Validation RMSE	Validation R ²	Validation MAPE	Test RMSE	Test R ²	Test MAPE
Linear Regression	0.8111	0.9935	0.5204%	0.6803	0.9909	0.6104%
XGBoost	0.8254	0.9933	0.5092%	0.7853	0.9898	0.611%
Decission Tree	0.8111	0.9935	0.5204%	0.6803	0.9909	0.6104%
Random Forest	0.9377	0.9871	0.8072%	1.0115	0.973	1.2315%
MLP	0.7727	0.9941	0.5257%	0.7052	0.9907	0.5931%

IntegrIA – AI TP Stress forecasting model

Linear Regression results

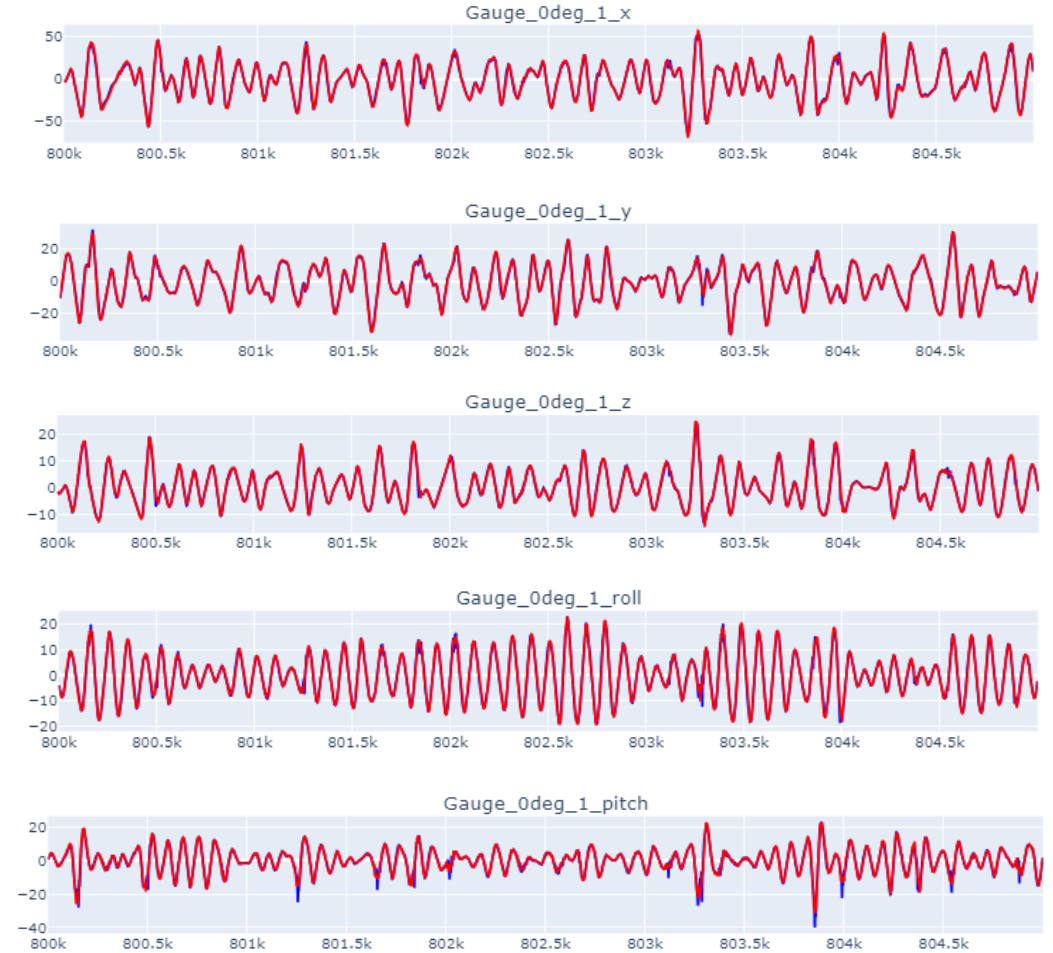
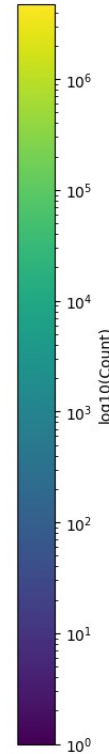
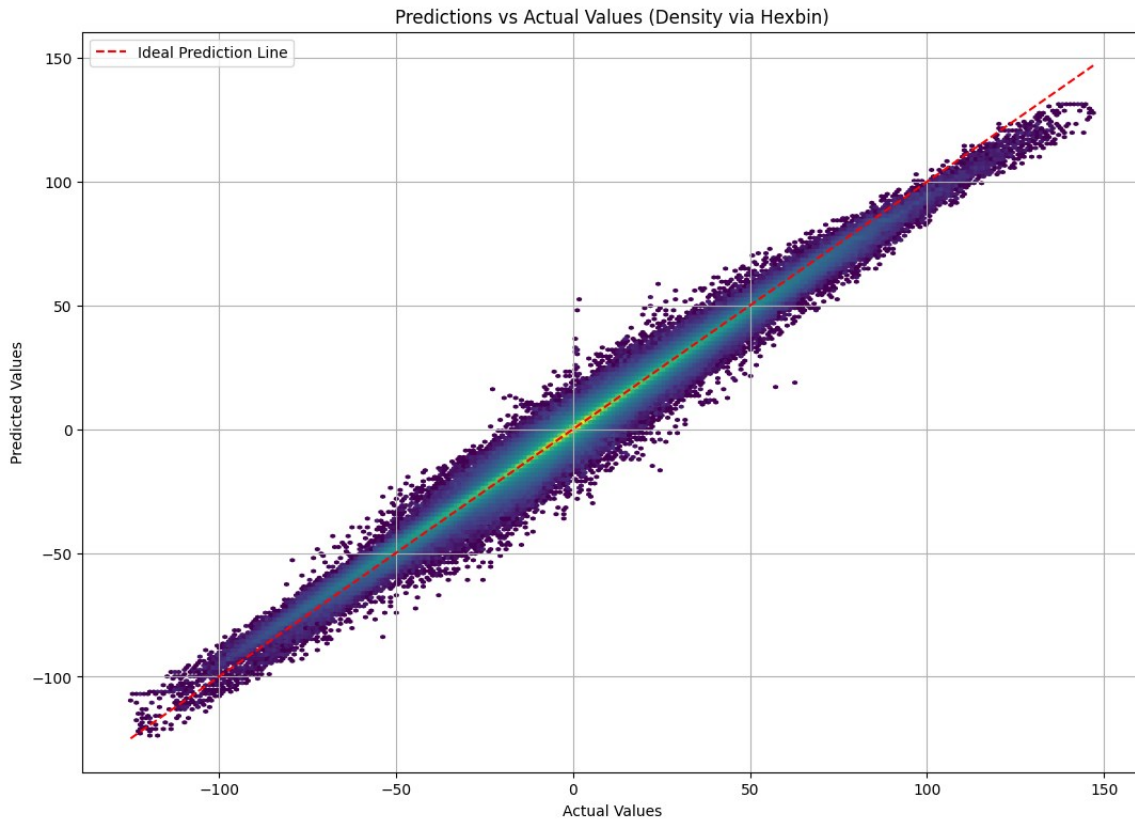

IntegrIA – AI TP Stress forecasting model

TP STRESS FORECASTING (Time Series models)

Neural Network (LSTM Seq2Seq encoder-decoder)

Input(5*480): Accelerations [$t_{-480} - t_0$]

Output(18*40): Stress from [$t_0 - t_{+40}$]



+
MinMaxScaler()

	RMSE	MAPE
Validación	6.797	6.1%
Test	6.802	6.12%

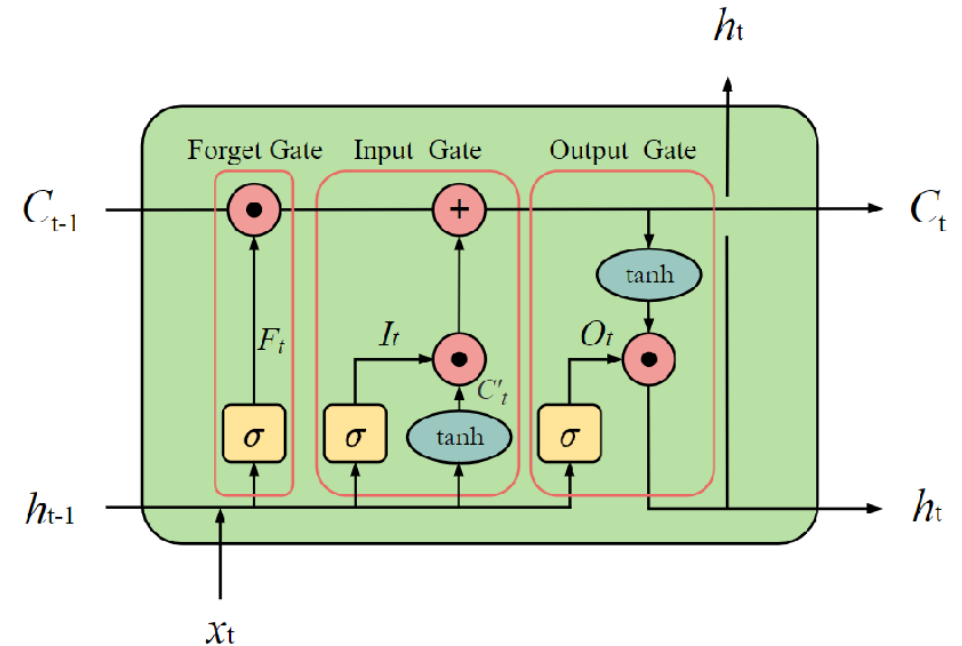

IntegrIA – AI TP Stress forecasting model

Output(18*40): Stress from t_0, t_{+40}

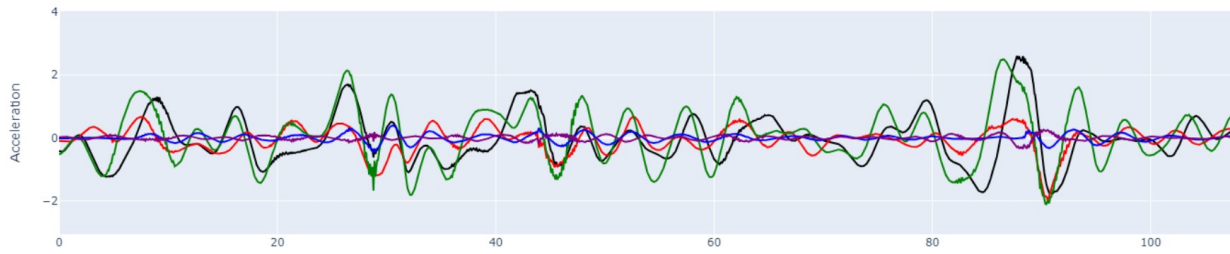
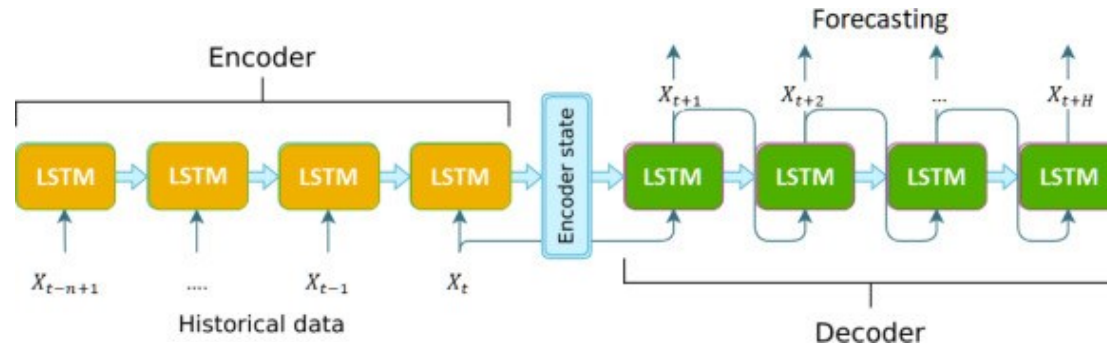
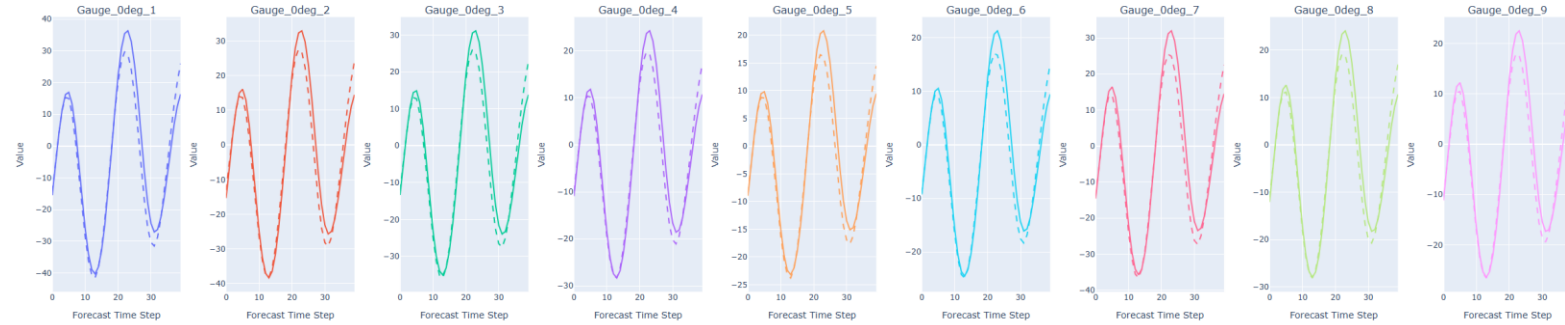

- x acceleration
- y acceleration
- z acceleration
- Roll acceleration
- Pitch acceleration

Input(5*480): Accel. from t_{-480}, t_0

Index

1. - **IntegrIA project Introduction**
2. - **Digital model architecture**
3. - **AI models for TP Stress forecasting**
4. - **Metoceanic AI model**

IntegrIA – Metaoceanic AI model

- Objective: Predict meteocean parameters to estimate the sea state in the harshlab.
 - Significant wave height (m)
 - Peak period (s)
 - Wave direction (deg)
 - Gamma (float)
- Data available from Soffar Spotter: registries every 30 minutes from 2024-07-18 7:00 to 2024-12-31 23:00



IntegrIA – Metaoceanic AI model

Significant Wave Height (m) - 30min horizon

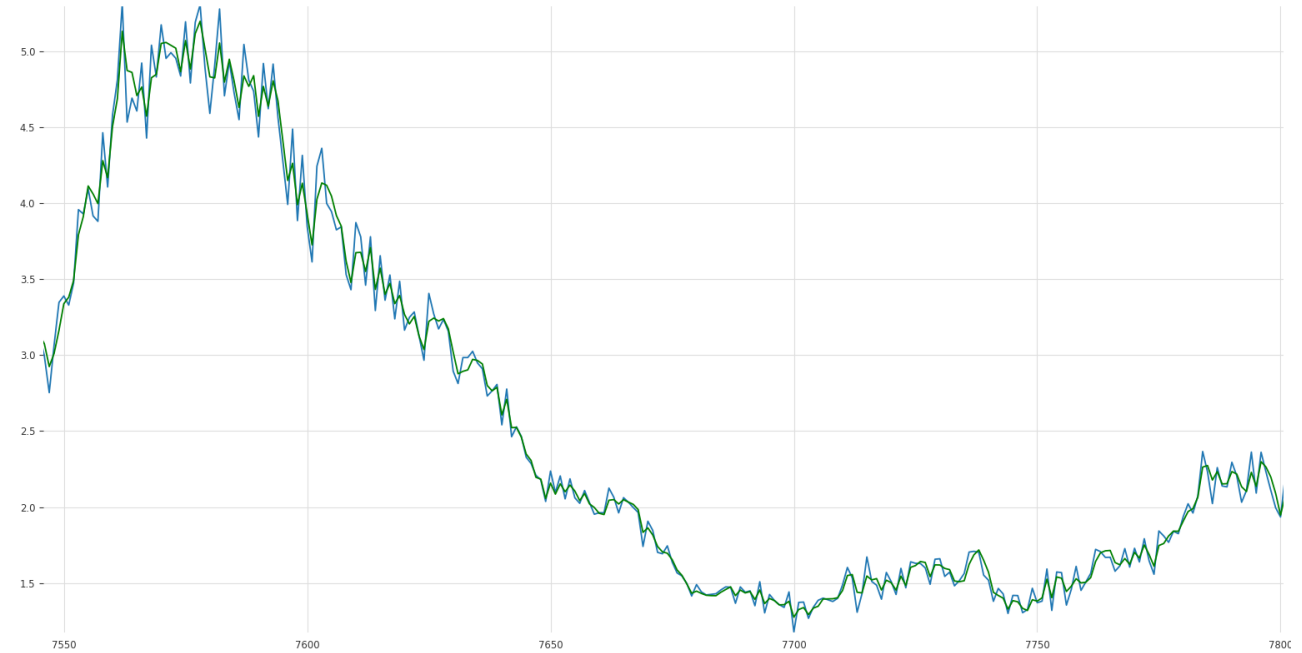
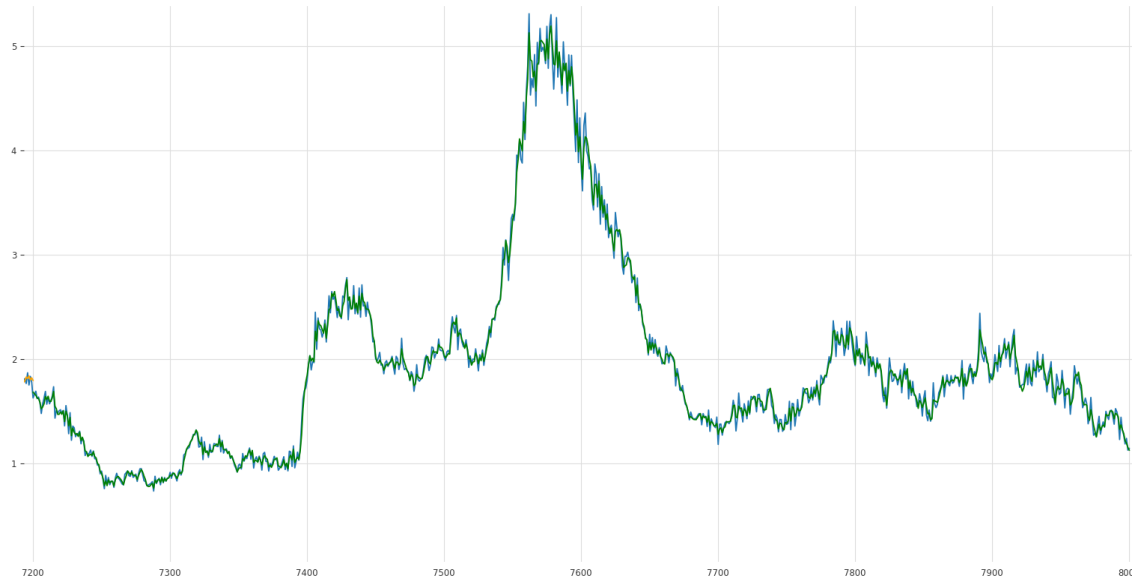

	RMSE	MAPE
Training	0.126	5.88%
Test	0.101	5.22%

IntegrIA – Metaoceanic AI model

Peak Period (s)- 30min horizon

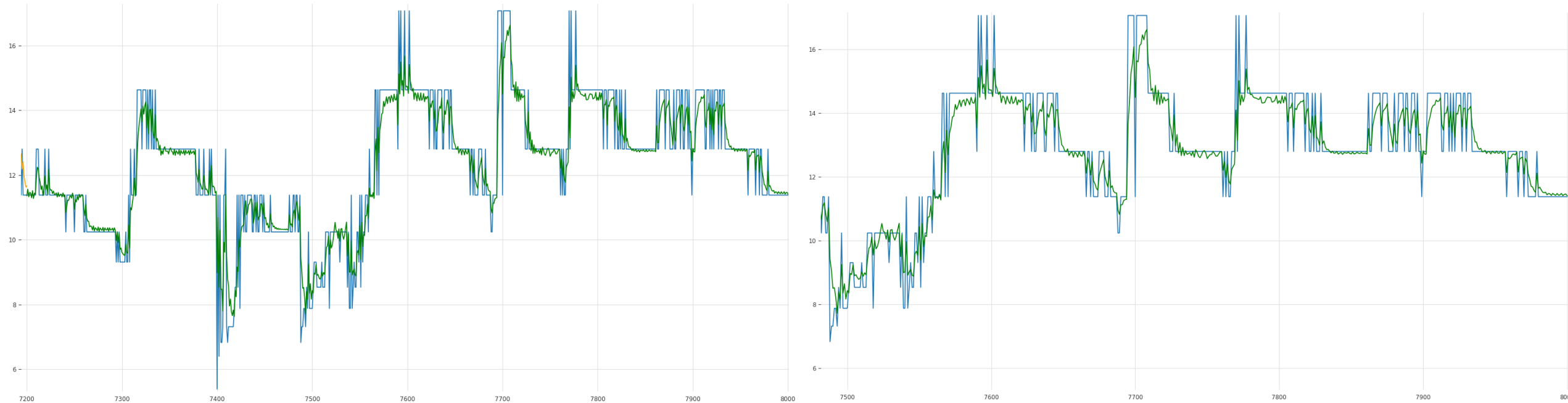

	RMSE	MAPE
Training	1.517	0.076%
Test	0.609	0.052%

IntegrIA – Metaoceanic AI model

Wave Direction (deg) - 30min horizon

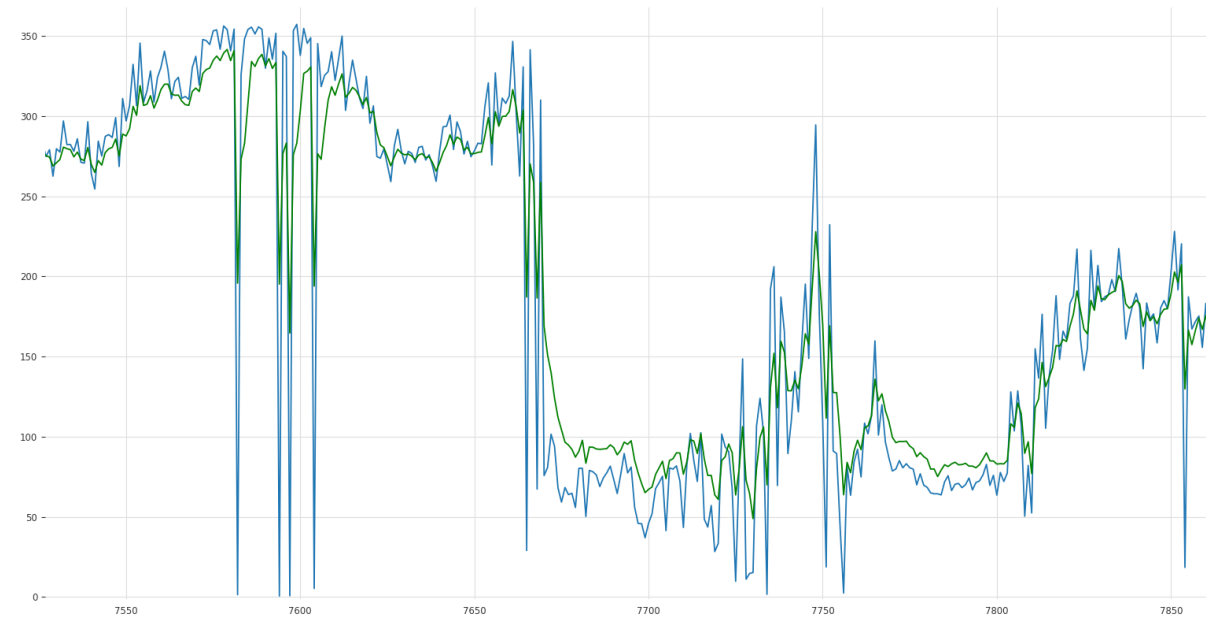
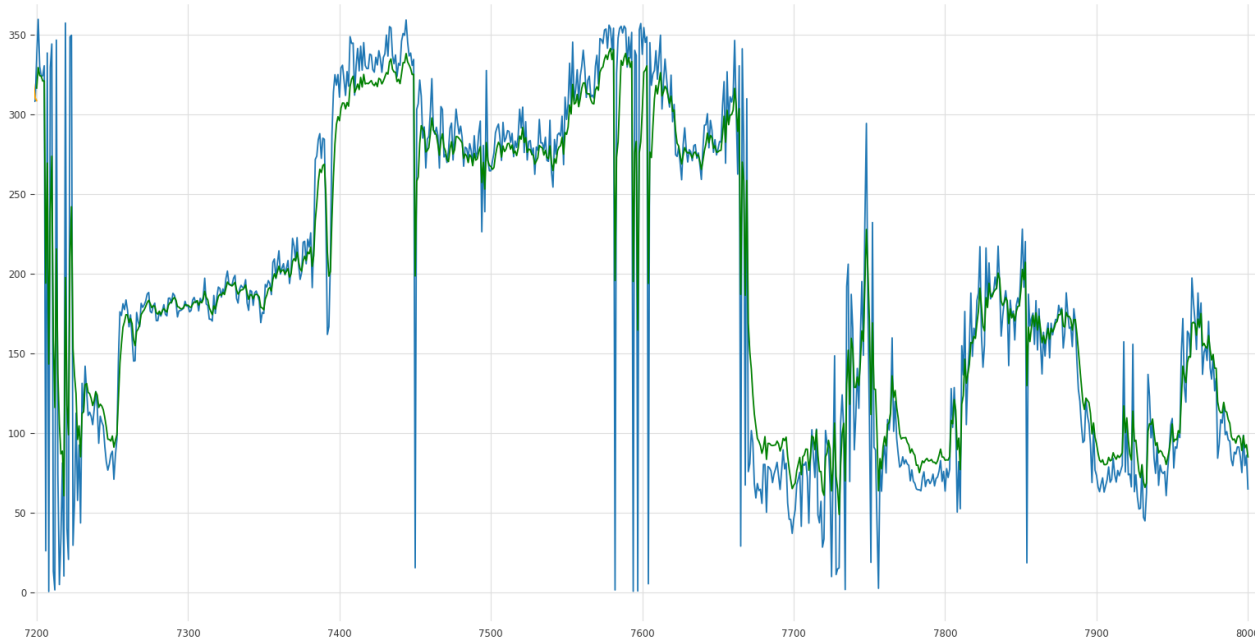

	RMSE	MAPE
Training	73.774	5.334%
Test	25.995	2.716%

INTEGRIA

Research into structural INTEGRity in floating offshore wind using models based on Artificial Intelligence

Eskerrik asko!
¡Gracias!

Nautilus
Floating Solutions

ALERION



ditrel



ERREKA

GLUAL
ENERGY

HINE

ayesa



innomat
coatings

keracoat
CERAMIC COATINGS

LAULAGUN
bearings

NAVACEL
Process Industries



tecnal:a
MEMBER OF BASQUE RESEARCH
& TECHNOLOGY ALLIANCE

ceit
MEMBER OF
BASQUE RESEARCH
& TECHNOLOGY ALLIANCE

cidetec
MEMBER OF BASQUE RESEARCH
& TECHNOLOGY ALLIANCE

Cluster Energía
BASQUE ENERGY CLUSTER

